



Traffic Count Consultants, Inc.

Woodinville, WA 98072

Phone: (425) 861-8866 FAX: (425) 861-8877

Turning Movement Diagram

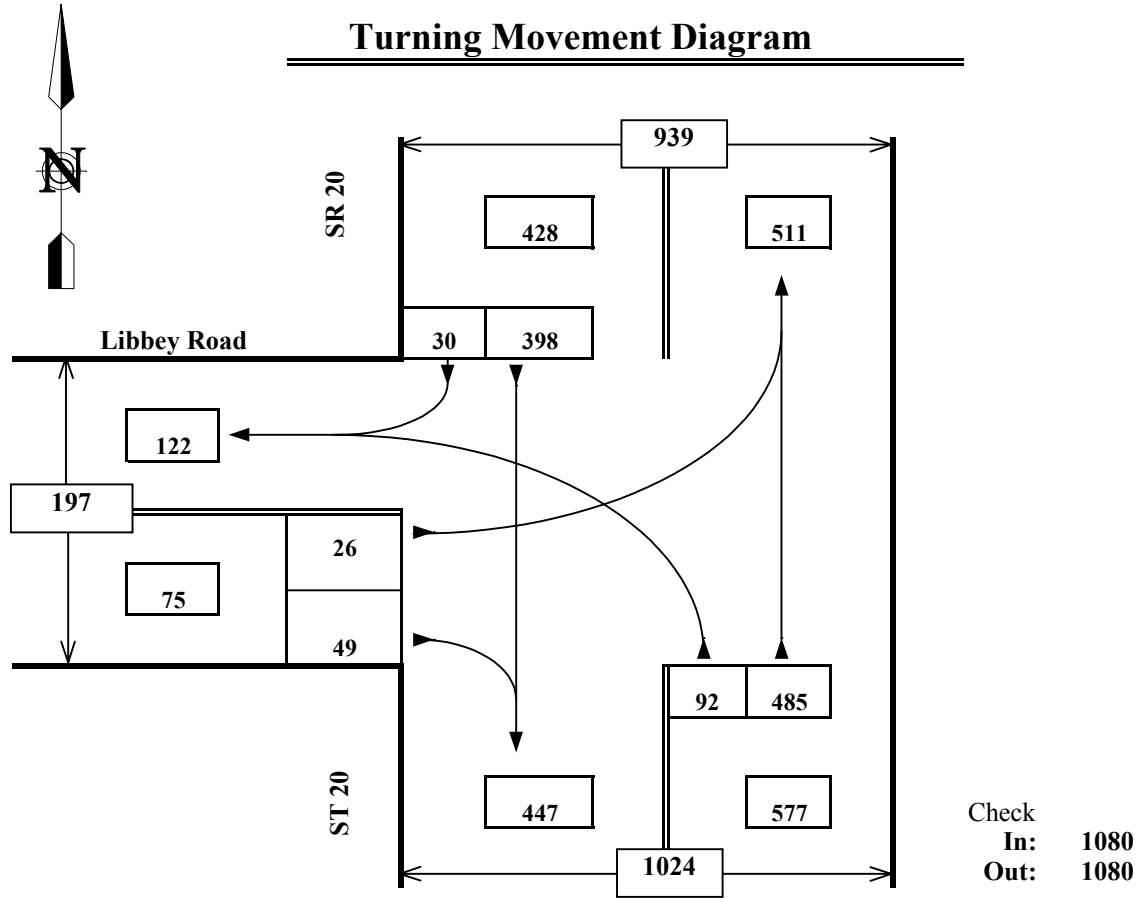

Intersection: SR 20 @ Libbey Road
Location: Whidbey Island
Date of Count: Wed 4/13/05
Peak Period: 5:30 P - 6:30 P
Checked By: CMW
Prepared For: Island County

| | %HV | PHF |
|---------------------|-------------|-------------|
| EB | 1.3% | 0.78 |
| WB | n/a | n/a |
| NB | 4.5% | 0.81 |
| SB | 3.0% | 0.79 |
| Intersection | 3.7% | 0.90 |



Traffic Count Consultants, Inc.

Woodinville, WA 98072

Phone: (425) 861-8866 FAX: (425) 861-8877

Vehicle Volume Summary

Intersection: SR 20 @ Libbey Road
 Location: Whidbey Island

Date of Count: Wed 4/13/05
 Checked By: CMW

| Time Interval Ending at | From North on (SB) SR 20 | | | | From South on (NB) ST 20 | | | | From East on (WB) n/a | | | | From West on (EB) Libbey Road | | | | Interval Total |
|----------------------------|-----------------------------|---|------|-----|-----------------------------|-----|------|---|--------------------------|---|---|---|----------------------------------|----|---|-----|-------------------|
| | T | L | S | R | T | L | S | R | T | L | S | R | T | L | S | R | |
| 3:45 P | 3 | 0 | 110 | 7 | 5 | 19 | 119 | 0 | 0 | 0 | 0 | 0 | 4 | 7 | 0 | 12 | 274 |
| 4:00 P | 1 | 0 | 102 | 6 | 4 | 16 | 103 | 0 | 0 | 0 | 0 | 0 | 0 | 3 | 0 | 11 | 241 |
| 4:15 P | 5 | 0 | 105 | 9 | 5 | 19 | 98 | 0 | 0 | 0 | 0 | 0 | 3 | 9 | 0 | 28 | 268 |
| 4:30 P | 6 | 0 | 114 | 11 | 4 | 18 | 88 | 0 | 0 | 0 | 0 | 0 | 1 | 5 | 0 | 20 | 256 |
| 4:45 P | 2 | 0 | 118 | 14 | 5 | 16 | 90 | 1 | 0 | 0 | 0 | 0 | 0 | 4 | 0 | 19 | 262 |
| 5:00 P | 3 | 0 | 126 | 5 | 4 | 15 | 90 | 1 | 0 | 0 | 0 | 0 | 0 | 3 | 0 | 27 | 267 |
| 5:15 P | 3 | 0 | 101 | 10 | 4 | 15 | 106 | 1 | 0 | 0 | 0 | 0 | 0 | 7 | 0 | 13 | 253 |
| 5:30 P | 3 | 0 | 114 | 8 | 4 | 16 | 104 | 0 | 0 | 0 | 0 | 0 | 0 | 4 | 0 | 12 | 258 |
| 5:45 P | 3 | 0 | 126 | 9 | 4 | 16 | 115 | 0 | 0 | 0 | 0 | 0 | 0 | 9 | 0 | 14 | 289 |
| 6:00 P | 3 | 0 | 99 | 7 | 5 | 21 | 98 | 0 | 0 | 0 | 0 | 0 | 0 | 7 | 0 | 17 | 249 |
| 6:15 P | 4 | 0 | 75 | 2 | 9 | 25 | 125 | 0 | 0 | 0 | 0 | 0 | 1 | 4 | 0 | 10 | 241 |
| 6:30 P | 3 | 0 | 98 | 12 | 8 | 30 | 147 | 0 | 0 | 0 | 0 | 0 | 0 | 6 | 0 | 8 | 301 |
| Total Survey | 39 | 0 | 1288 | 100 | 61 | 226 | 1283 | 3 | 0 | 0 | 0 | 0 | 9 | 68 | 0 | 191 | 3159 |

5:30 P to 6:30 P Peak Hour Summary

| | | | | | | | | | | | | | | | | | |
|----------|------|---|-----|----|------|----|-----|---|-----|---|---|---|------|---|----|------|------|
| Total | 13 | 0 | 398 | 30 | 26 | 92 | 485 | 0 | 0 | 0 | 0 | 1 | 26 | 0 | 49 | 1080 | |
| Approach | 428 | | | | 577 | | | | 0 | | | | 75 | | | | 1080 |
| %HV | 3% | | | | 5% | | | | n/a | | | | 1% | | | | 4% |
| PHF | 0.79 | | | | 0.81 | | | | n/a | | | | 0.78 | | | | 0.90 |

PEDESTRIANS ACROSS:

Interval: 1
2
3
4
5
6
7
8

Legend: T= Number of heavy vehicles (greater than 4 wheels)
 L= Left -Turn
 S= Straight
 R= Right-Turn
 HV= Heavy Vehicles
 PHF= Peak hour Factor (Peak hour volume / (4*Highest 15 Ped Totals:

| North | South | East | West | Intv'l | Sum |
|-------|-------|------|------|--------|-----|
| | | | | 1 | 0 |
| | | | | 2 | 0 |
| | | | | 3 | 0 |
| | | | | 4 | 0 |
| | | | | 5 | 0 |
| | | | | 6 | 0 |
| | | | | 7 | 0 |
| | | | | 8 | 0 |
| 0 | 0 | 0 | 0 | | 0 |

(NO PEDS)

Prepared For: Island County

TM05b033-08p