



Traffic Count Consultants, Inc.

Woodinville, WA 98072

Phone: (425) 861-8866 FAX: (425) 861-8877

Turning Movement Diagram

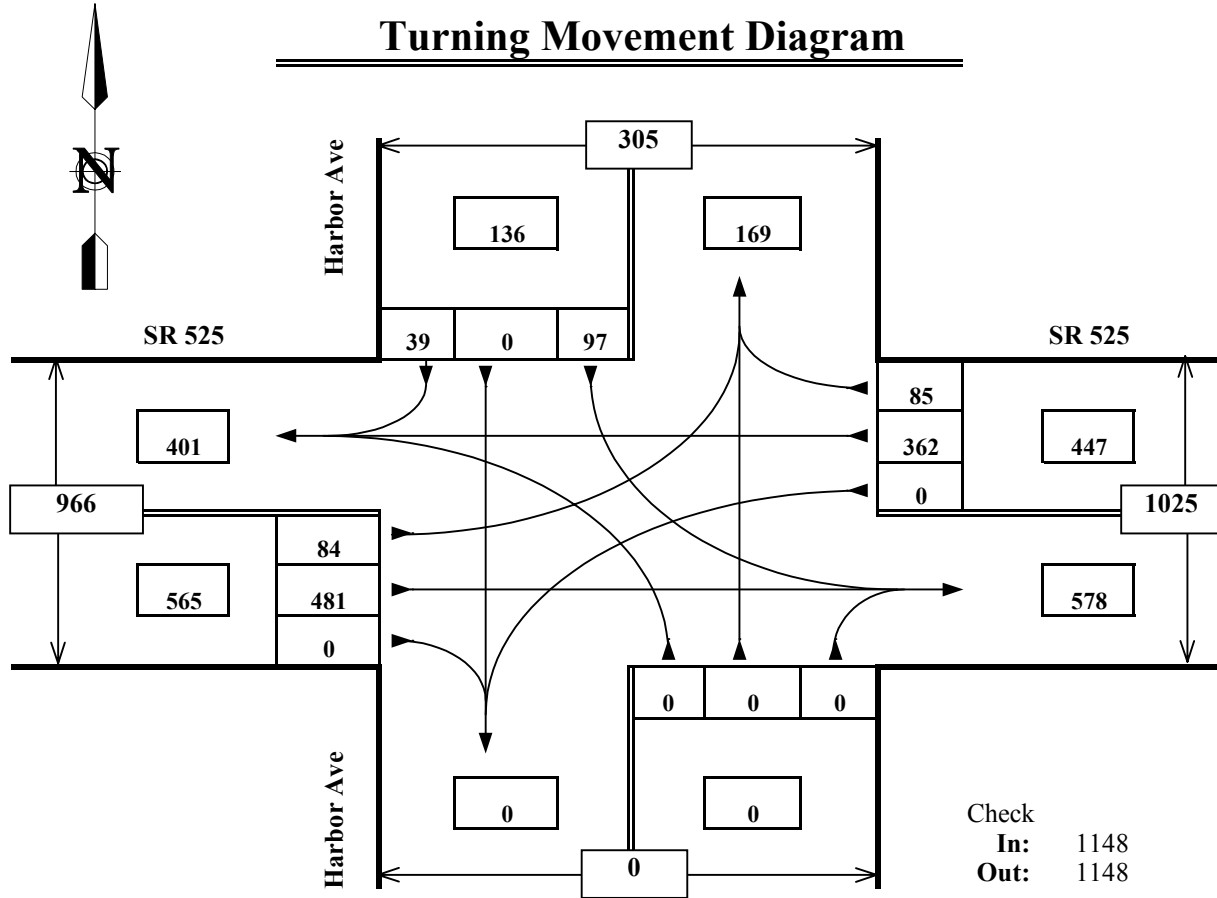

Intersection: SR 525 @ Harbor Ave
Location: Whidbey Island
Date of Count: Tues 4/12/05
Peak Period: 3:45 P - 4:45 P
Checked By: CMW

Prepared For: Island County

	%HV	PHF
EB	1.8%	0.92
WB	2.9%	0.84
NB	n/a	n/a
SB	1.5%	0.79
Intersection	2.2%	0.92



Traffic Count Consultants, Inc. Woodinville, WA 98072

Phone: (425) 861-8866

FAX: (425) 861-8877

Vehicle Volume Summary

Intersection: SR 525 @ Harbor Ave
Location: Whidbey Island

Date of Count: Tues 4/12/05
Checked By: CMW

Time Interval Ending at	From North on (SB) Harbor Ave				From South on (NB) Harbor Ave				From East on (WB) SR 525				From West on (EB) SR 525				Interval Total
	T	L	S	R	T	L	S	R	T	L	S	R	T	L	S	R	
3:45 P	0	20	0	13	0	0	0	0	6	0	125	16	8	9	111	0	294
4:00 P	1	22	0	14	0	0	0	0	5	0	72	15	1	29	124	0	276
4:15 P	0	25	0	7	0	0	0	0	4	0	100	22	3	21	117	0	292
4:30 P	1	19	0	6	0	0	0	0	4	0	84	21	4	18	120	0	268
4:45 P	0	31	0	12	0	0	0	0	0	0	106	27	2	16	120	0	312
5:00 P	0	23	0	10	0	0	0	0	1	0	67	16	4	12	98	0	226
5:15 P	0	26	0	9	0	0	0	0	3	0	125	16	2	5	136	0	317
5:30 P	0	21	0	10	0	0	0	0	0	0	81	28	2	13	134	0	287
5:45 P	2	23	0	7	0	0	0	0	1	0	121	11	0	12	122	0	296
6:00 P	0	18	0	4	0	0	0	0	1	0	73	12	0	6	98	0	211
6:15 P	0	16	0	9	0	0	0	0	1	0	110	14	0	7	125	0	281
6:30 P	1	13	0	13	0	0	0	0	1	0	65	11	1	3	90	0	195
Total Survey	5	257	0	114	0	0	0	0	27	0	1129	209	27	151	1395	0	3255

3:45 P to 4:45 P Peak Hour Summary

Total	2	97	0	39	0	0	0	0	13	0	362	85	10	84	481	0	1148
Approach	136				0				447				565				1148
%HV	1%				n/a				3%				2%				2%
PHF	0.79				n/a				0.84				0.92				0.92

PEDESTRIANS :
(NO PEDS)

North South East West Totals

1					0
2					0
3					0
4					0
5					0
6					0
7					0
8					0
9					0
10					0
	0	0	0	0	0

Legend: T= Number of heavy vehicles (greater than 4 wheel
 L= Left -Turn
 S= Straight
 R= Right-Turn
 HV= Heavy Vehicles
 PHF= Peak hour Factor (Peak hour volume / (4*High

Prepared For: Island County

TM05b033-13p