



Traffic Count Consultants, Inc.

Woodinville, WA 98072

Phone: (425) 861-8866 FAX: (425) 861-8877

Turning Movement Diagram

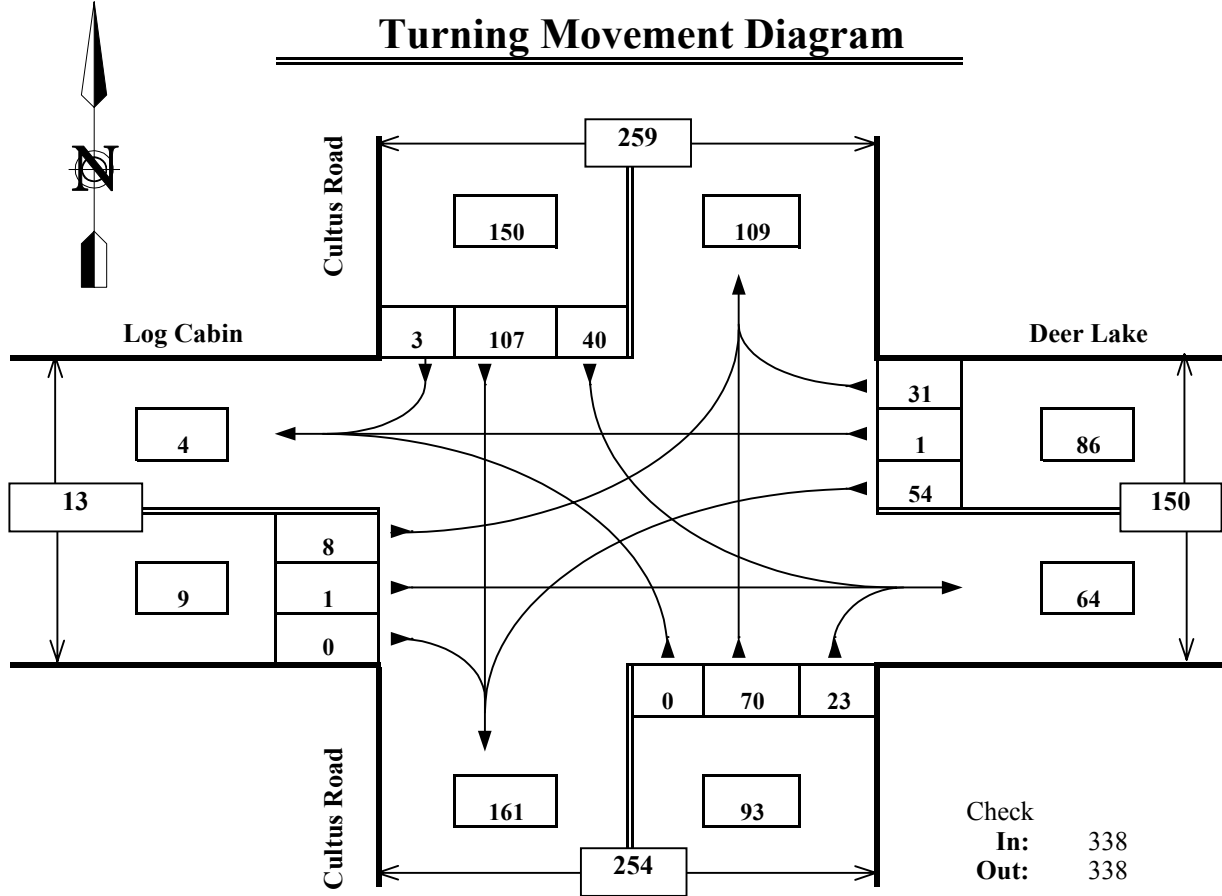

Intersection: Cultus Bay Road/Deer Lake Road @ Log Cabin
Location: Whidbey Island
Date of Count: thurs 4/12/05
Peak Period: 4:45 P - 5:45 P
Checked By: CMW

Prepared For: Island County

	%HV	PHF
EB	0.0%	0.45
WB	1.2%	0.60
NB	4.3%	0.83
SB	0.7%	0.85
Intersection	1.8%	0.93



Traffic Count Consultants, Inc. Woodinville, WA 98072

Phone: (425) 861-8866

FAX: (425) 861-8877

Vehicle Volume Summary

Intersection: Cultus Bay Road/Deer Lake Road @ Log Cabin
Location: Whidbey Island

Date of Count: thurs 4/12/05
Checked By: CMW

Time Interval Ending at	From North on (SB) Cultus Road				From South on (NB) Cultus Road				From East on (WB) Deer Lake				From West on (EB) Log Cabin				Interval Total
	T	L	S	R	T	L	S	R	T	L	S	R	T	L	S	R	
3:45 P	1	18	22	3	0	0	22	7	0	9	0	4	0	0	0	0	85
4:00 P	0	11	13	1	1	0	11	7	0	13	1	6	0	3	0	0	66
4:15 P	0	6	18	0	2	0	20	7	2	11	0	10	0	2	0	0	74
4:30 P	3	12	18	1	2	0	15	8	1	22	0	5	0	1	0	0	82
4:45 P	2	9	26	2	1	0	14	4	0	6	0	4	0	0	0	0	65
5:00 P	0	7	22	2	1	0	16	8	0	26	0	10	0	0	0	0	91
5:15 P	0	12	31	1	2	0	15	7	0	6	0	10	0	3	1	0	86
5:30 P	0	13	25	0	0	0	16	3	1	18	1	8	0	5	0	0	89
5:45 P	1	8	29	0	1	0	23	5	0	4	0	3	0	0	0	0	72
6:00 P	1	6	19	1	0	0	20	9	0	14	0	10	0	0	0	0	79
6:15 P	0	7	21	2	0	0	10	11	0	6	0	6	0	0	0	1	64
6:30 P	1	10	25	1	0	0	6	6	0	25	1	7	0	0	0	0	81
Total Survey	9	119	269	14	10	0	188	82	4	160	3	83	0	14	1	1	934

4:45 P to 5:45 P Peak Hour Summary

Total	1	40	107	3	4	0	70	23	1	54	1	31	0	8	1	0	338
Approach	150				93				86				9				338
%HV	1%				4%				1%				0%				2%
PHF	0.85				0.83				0.60				0.45				0.93

PEDESTRIANS :

(NO PEDS)

Legend: T= Number of heavy vehicles (greater than 4 wheel
 L= Left -Turn
 S= Straight
 R= Right-Turn
 HV= Heavy Vehicles
 PHF= Peak hour Factor (Peak hour volume / (4*High

	North	South	East	West	Totals
1					0
2					0
3					0
4					0
5					0
6					0
7					0
8					0
9					0
10					0
	0	0	0	0	0

Prepared For: Island County